



Immediately join the Shimge Family by scanning:
<https://www.shimgepump.com>

SHIMGE PUMP INDUSTRY (ZHEJIANG) CO., LTD.

Add: Dayangcheng Industrial Zone, Daxi Town, Wenling City, Zhejiang Province, China

Tel: +86-576-86339960

Fax: +86-576-86337079

Email: admin@shimge.com

Version No.202007

SHIMGE[®]
..... ———— *for better life*

YS Series Stainless Steel Single Stage Centrifugal Pump

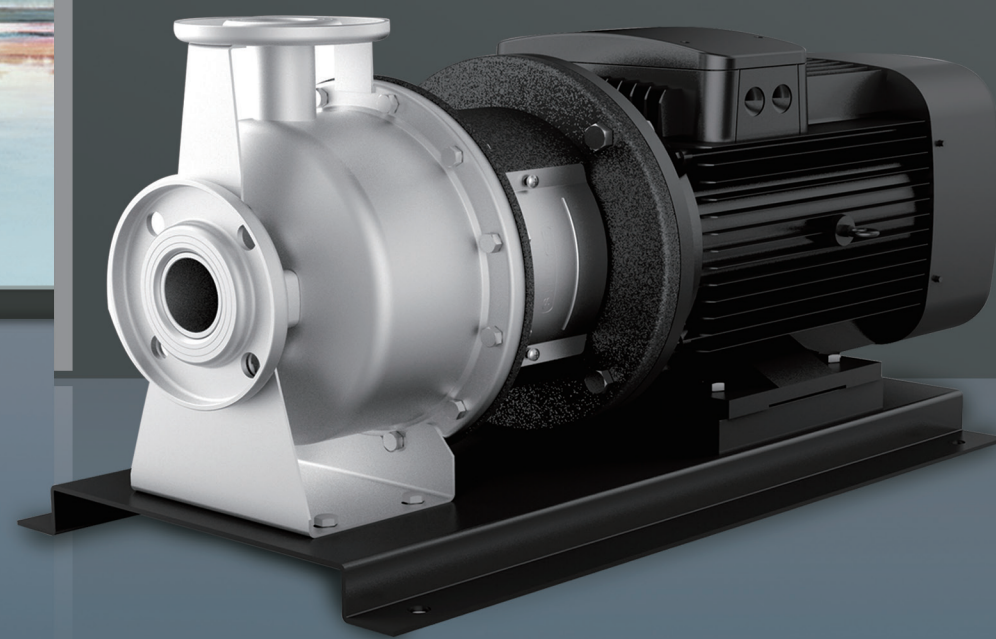



DIRECTORY

01P

- Product Overview
 - Model Description
-

02P

- Operating Conditions
 - Structural Features
-

03P

- Applications
 - Spectrum Diagram
-

05P

- Electric Motor
-

07P

- Product Structure
 - Installation Conditions
-

12P

- Technical Data
-

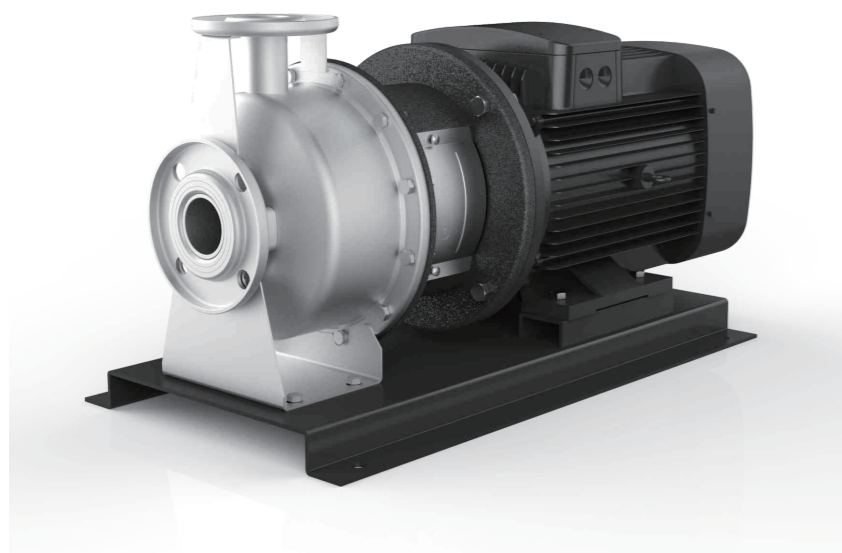

Product Overview

Made by adopting such advanced technologies as stamping, bulging and welding of stainlesssteel plates, YS stainless steel horizontal single stage centrifugal pump is a new generation of domestically initiative centrifugal pump, which can replace traditional IS pumps and general corrosion-resistance pumps. It has such features as good-looking appearance, lightweight structure, high efficiency and energy saving, robustness, resistance to light corrosion, and low noise.

Model Description

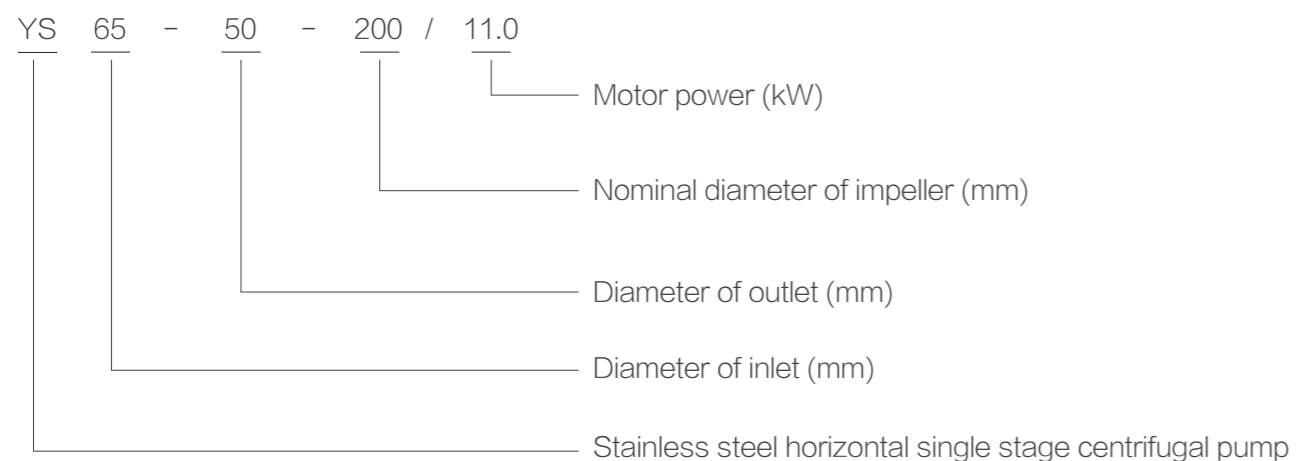

Operating Conditions

The use of YS pump is restricted by the following conditions:

1. Clean, thin, and non-flammable & non-explosive liquid that does not contain solid particles and fibers;
2. Liquid at the temperature between -20°C and $+100^{\circ}\text{C}$;
3. Maximum ambient temperature: $+40^{\circ}\text{C}$;
4. Maximum altitude: 1000m;
5. Maximum working pressure: 1.0MPa

Structural Features



Motor

High efficiency and energy saving
Angular contact bearing is adopted at the drive end, so that the motor operates more safely with lower noise.



Pump body

Stainless steel stamping and welding
Good discharge capacity
Reliable hydraulic self-balancing



Pump cover

Professional style design
Heightened design, equipped with protective cover
Surface electrophoresis treatment
Good ventilation and heat dissipation



Pump shaft

Sleeve coupling type
100,000 times of reliability testing
Stainless steel material
Dynamic balancing



Impeller

German casting technology
Efficient hydraulic design
Stainless steel material

The international popular modular design is adopted to reduce the unnecessary parts and components, guarantee the universality of parts, and facilitate purchasing, manufacturing and maintenance.

Applications

YS stainless steel horizontal single stage centrifugal pump is a multi-functional product with a wide range of applications, which can convey various media including water or industrial liquids, applicable to different ranges of temperature, flow and pressure. Its typical applications mainly include the following:

- Water supply: Filtering, transmission, sectionalized water supply, and manifold pressurization;
- Industrial pressurization: Process water system and cleaning system;
- Industrial liquid conveying: Boiler water supply, condensing system, cooling and air conditioning system, machine matching, and weak acid and alkali conveying;
- Water treatment: Distillation system or separator, and swimming pool, etc.;
- Farm irrigation, and medicine and health, etc.

Spectrum Diagram

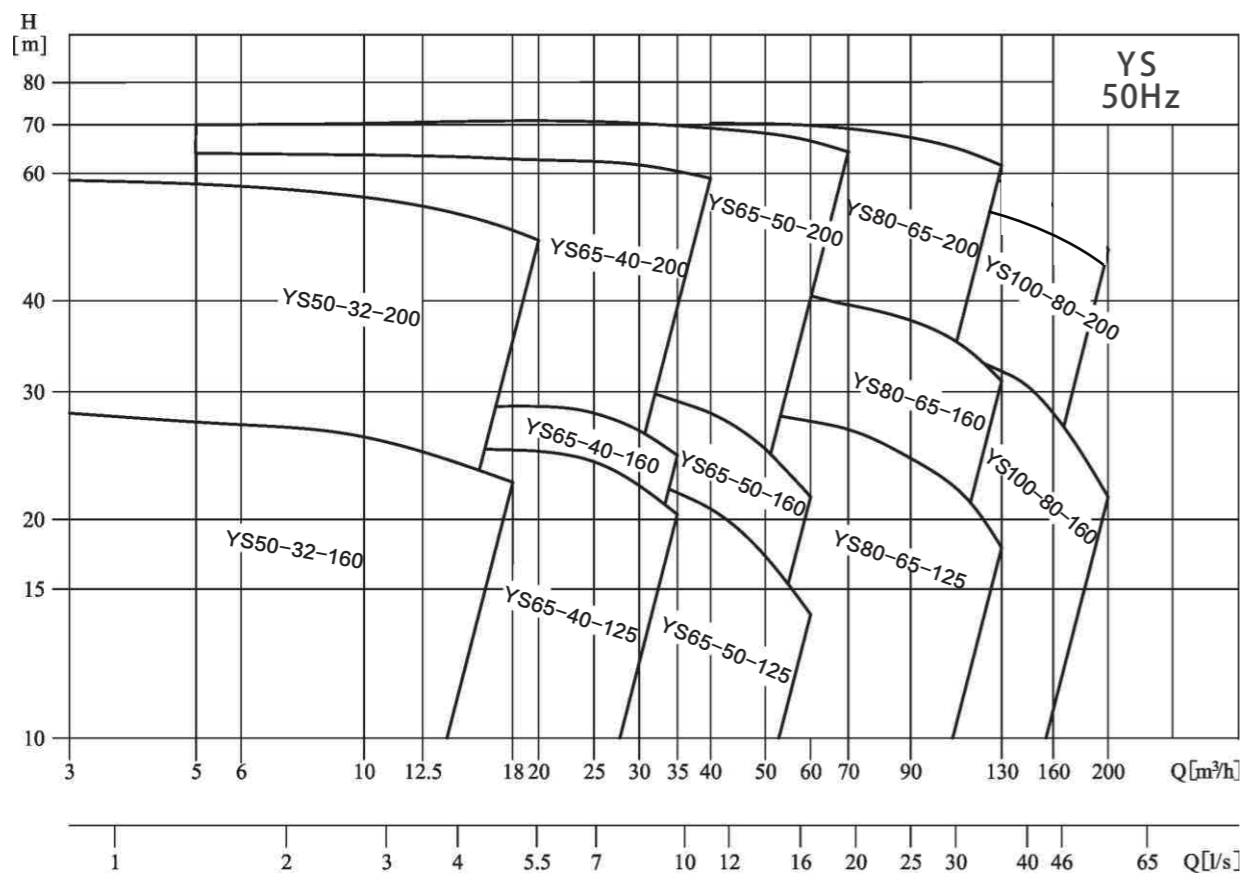

No.	Model	Flow rate (m³/h)	Lift (m)	Synchronous speed (r/min)	Standard motor voltage [V]	
					1×220V P ₂ [kW]	3×380V P ₂ [kW]
1	YS50-32-160/1.5	12.5	20	3000	1.5	1.5
2	YS50-32-160/2.2	12.5	25		2.2	2.2
3	YS50-32-200/3	12.5	32		/	3
4	YS50-32-200/4	12.5	42		/	4
5	YS50-32-200/5.5	12.5	54		/	5.5
6	YS65-40-125/1.5	25	13		1.5	1.5
7	YS65-40-125/2.2	25	18		2.2	2.2
8	YS65-40-125/3	25	24		/	3
9	YS65-40-160/4	25	28		/	4
10	YS65-40-200/5.5	25	36		/	5.5
11	YS65-40-200/7.5	25	46		/	7.5
12	YS65-40-200/11	25	62		/	11
13	YS65-50-125/3	50	13		/	3
14	YS65-50-125/4	50	18		/	4
15	YS65-50-160/5.5	50	25		/	5.5
16	YS65-50-200/7.5	50	32		/	7.5
17	YS65-50-200/9.2	50	40		/	9.2
18	YS65-50-200/11	50	48		/	11
19	YS65-50-200/15	50	58		/	15
20	YS65-50-200/18.5	50	68		/	18.5
21	YS80-65-125/5.5	100	13		/	5.5
22	YS80-65-125/7.5	100	18		/	7.5
23	YS80-65-125/9.2	100	23		/	9.2
24	YS80-65-160/11	100	27		/	11
25	YS80-65-160/15	100	36		/	15
26	YS80-65-200/18.5	100	45		/	18.5
27	YS80-65-200/22	100	53		/	22
28	YS80-65-200/30	100	66		/	30
29	YS100-80-160/11	160	15		/	11
30	YS100-80-160/15	160	22		/	15
31	YS100-80-160/18.5	160	28		/	18.5
32	YS100-80-200/22	160	33		/	22

Motor

- **Structure:** All-series totally enclosed air-cooled three-phase asynchronous standard motor, in which single-phase motor is optional for the power range of 1.1kW ~ 2.2kW.
- **Motor protection:** Single-phase motor is equipped with the built-in thermal protector, and three-phase motor shall be connected to the motor starter according to local regulations.
- **Ambient temperature:** $\leq 40^{\circ}\text{C}$; in an environment above this temperature, or when the motor is installed at an altitude above 1000m, due to the lower air density, the cooling effect of motor weakens, the loss of windings and iron core increases, and the operating efficiency reduces, resulting in the drop in the output power (P2) of motor; in this case, a motor with higher output power must be selected, as shown in Figure 1.

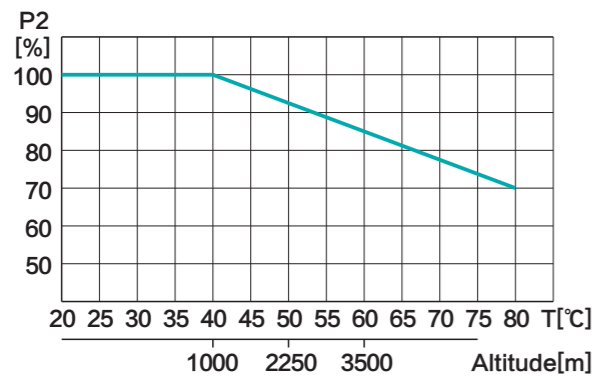

■ Figure 1 Relationship between motor output power (P2) and ambient temperature

IE2 Three-phase Motor

Rated power (kW)	Rated current(A)		Synchronous speed (r/min)	Power factor ($\cos\varphi$)	Efficiency (%)	Connection method	Motor bearing
	380(V)	415(V)					
1.5	3.34	3.06	3000	0.84	81.3	Y	6205ZZ
2.2	4.73	4.33		Y	6205ZZ		
3	6.19	5.67		Y	6206ZZ		
4	8.05	7.37		Δ	6206ZZ		
5.5	10.9	9.99		Δ	6308ZZ		
7.5	14.5	13.3		Δ	6308ZZ		
11	21.0	19.2		Δ	6309ZZ		
15	28.4	26.0		Δ	6309ZZ		
18.5	34.7	31.8		Δ	6309ZZ		
22	41.1	37.7		Δ	6311ZZ		
30	55.7	51.0		Δ	6312ZZ		

IE3 Three-phase Motor

Rated power (kW)	Rated current(A)		Synchronous speed (r/min)	Power factor ($\cos\varphi$)	Efficiency (%)	Connection method	Standard motor voltage [V]
	380(V)	415(V)					
1.5	3.22	2.95	3000	0.84	84.2	Y	6205ZZ
2.2	4.58	4.19		Y	6205ZZ		
3	6.02	5.51		Y	6206ZZ		
4	7.84	7.18		Δ	6206ZZ		
5.5	10.65	9.75		Δ	6308ZZ		
7.5	14.37	13.16		Δ	6308ZZ		
11	20.59	18.85		Δ	6309ZZ		
15	27.86	25.51		Δ	6309ZZ		
18.5	34.18	31.3		Δ	6309ZZ		
22	40.51	37.1		Δ	6311ZZ		
30	54.89	50.26		Δ	6312ZZ		

The product has two structures: integral structure for 1.5kW~4kW, and separated structure for 5.5kW and above; the separated structure is mainly composed of the five core components: pump body, impeller, pump cover, pump shaft, and motor, the motor is separable from the pump, the pump part is designed as the top pull-out structure, and all models are equipped with the standard motor and mechanical seal. The pump body is equivalent to a section of pipeline, and during the maintenance of pumps, the pump body can be sealed with the blank flange so as not to affect the normal operation of the system. The impeller is of an enclosed structure, and adopts the design of the twisted blade, which better ensures high hydraulic efficiency. The pump cover has the dual function of supporting the motor and sealing the pump body, and the seal between it and the pump body adopts the static seal "O-ring". The dimensions of inlet & outlet flanges of the pump meet the stipulations of such standards as GB/T 17241.6, ISO 7005-2 and DIN 2501

■ Sectional views of the product

■ Separated structure

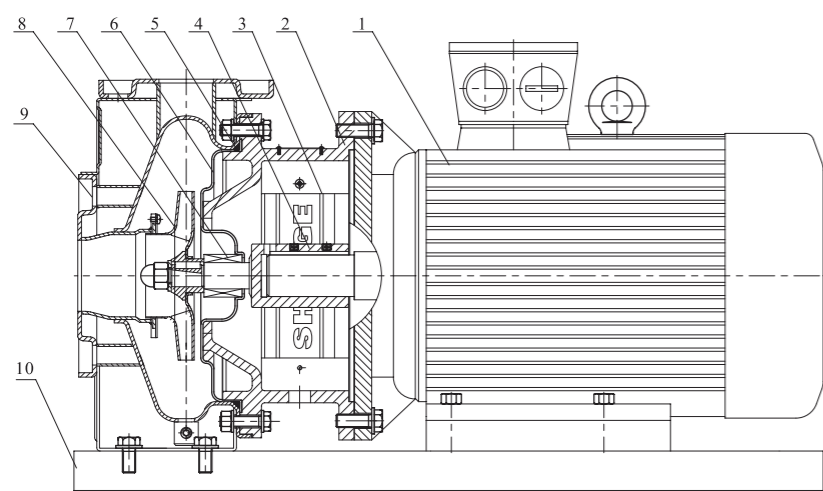

No.	Part name	Material
1	Motor	/
2	Pump cover	HT200
3	Protective plate	304
4	Pump shaft	304+45#
5	Rubber part	NBR
6	Baffle	304
7	Mechanical seal	FPM
8	Impeller	304
9	Pump body	304
10	Base	Q235A

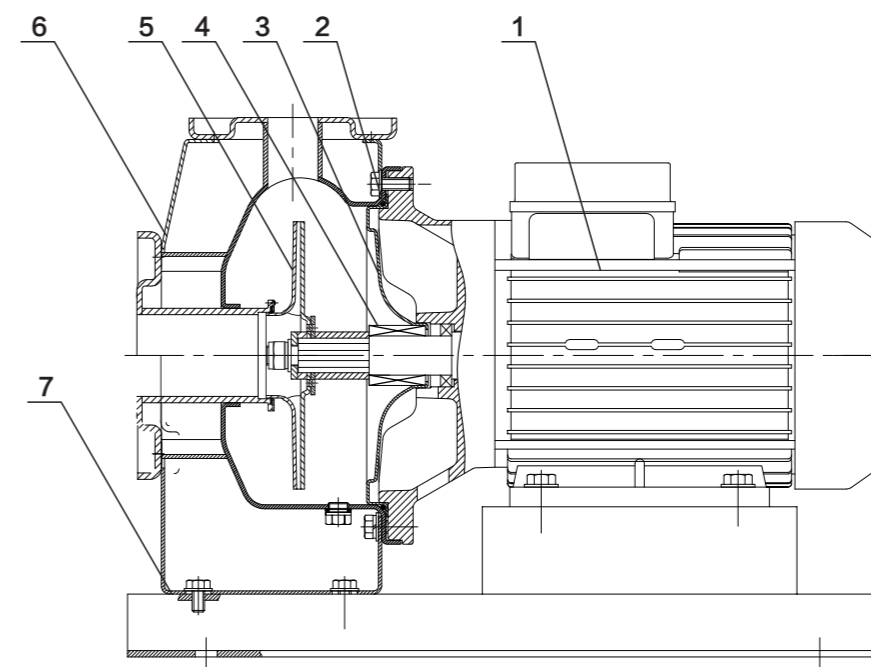

■ Integral structure

No.	Part name	Material
1	Motor	/
2	Rubber part	NBR
3	Baffle	304
4	Mechanical seal	FPM
5	Impeller	304
6	Pump body	304
7	Base	Q235A

≡ Installation Conditions

YS stainless steel horizontal single stage centrifugal pump adopts direct pump-shaft coupling, and it is composed of the pump, pump shaft and standard motor:

1. The pump shall be installed at a ventilated and anti-icing place;
2. The pump shall be so properly installed as to ensure that it is not affected by the tension of the system pipeline in use;
3. If the pump is installed outdoors, an appropriate outer cover must be provided to prevent water from entering or condensing in electrical components;
4. In order to facilitate inspection and maintenance, enough space must be left around the unit;
5. The electrical wiring device shall ensure that the pump is not damaged by phase loss, instable voltage, electrical leakage and overload;
6. The pump shall be horizontally mounted on the base, the horizontal direction is the inlet of pump, and the vertical direction is the outlet of pump.

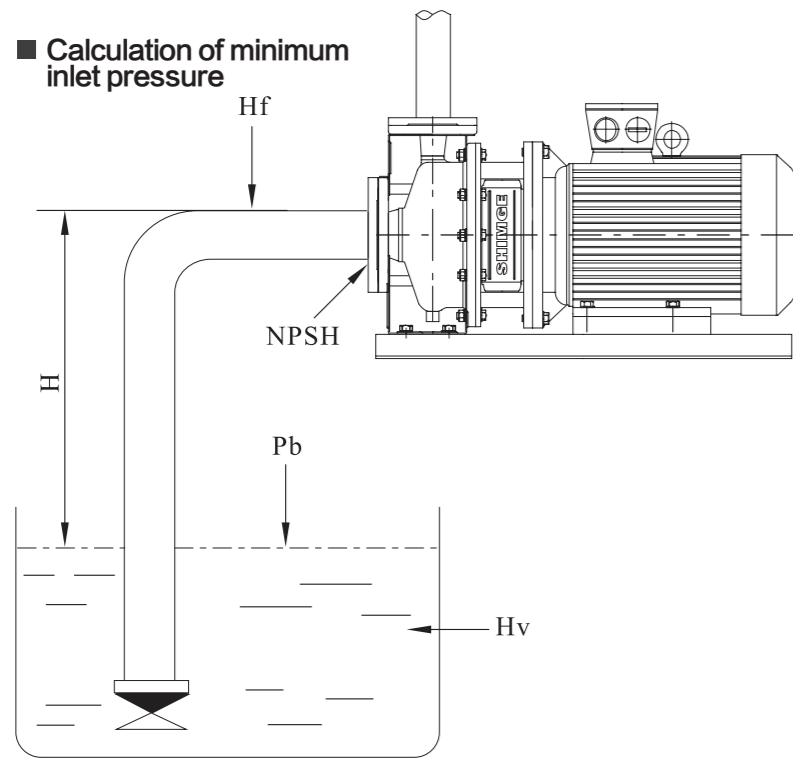

Inlet pressure: In order to ensure that the water pump is in the best operating state, and control the noise at the minimum level, the inlet pressure must be correctly calculated and set. If the pressure in the pump is lower than the vaporization pressure of the conveyed medium, cavitation will occur to the water pump, and in order to ensure a minimum pressure at the inlet of pump, the maximum suction height (m) can be calculated by the following formula:

$$H = P_b \times 10.2 - NPSH - H_f - H_v - H_s$$

P_b: Atmospheric pressure, unit: ba;

NPSH: Net positive suction height, unit: m (The specific value can be read from the numerical value corresponding to the maximum flow point of pump operation on the NPSH curve in the performance curves of corresponding models);

H_f: The inlet line loss at the maximum flow of pump operation, unit: m;

H_v: Vaporization pressure of liquid, unit: m (See the figure right for specific value);

H_s: Safety margin, unit: m, usually it takes 0.5m.

When calculated by the formula above, if the "H" value is positive, it indicates that the pump can operate at this suction height.

If the "H" value is negative, the pump can operate normally when the minimum inlet pressure reaches the pressure head of "H" m.

Notes: Usually the calculation above is not necessary, but the calculation is required under the following circumstances:

1. The liquid temperature is high;
2. The inlet conditions are poor;
3. The inlet pipeline is long, or the pump needs to be installed and used for suction;
4. The system pressure is too low;
5. The flow velocity of liquid is too high, causing a larger line loss.

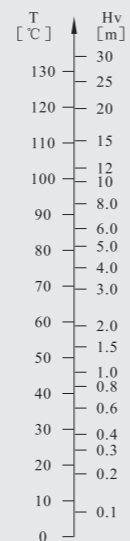

Examples of Performance Curves

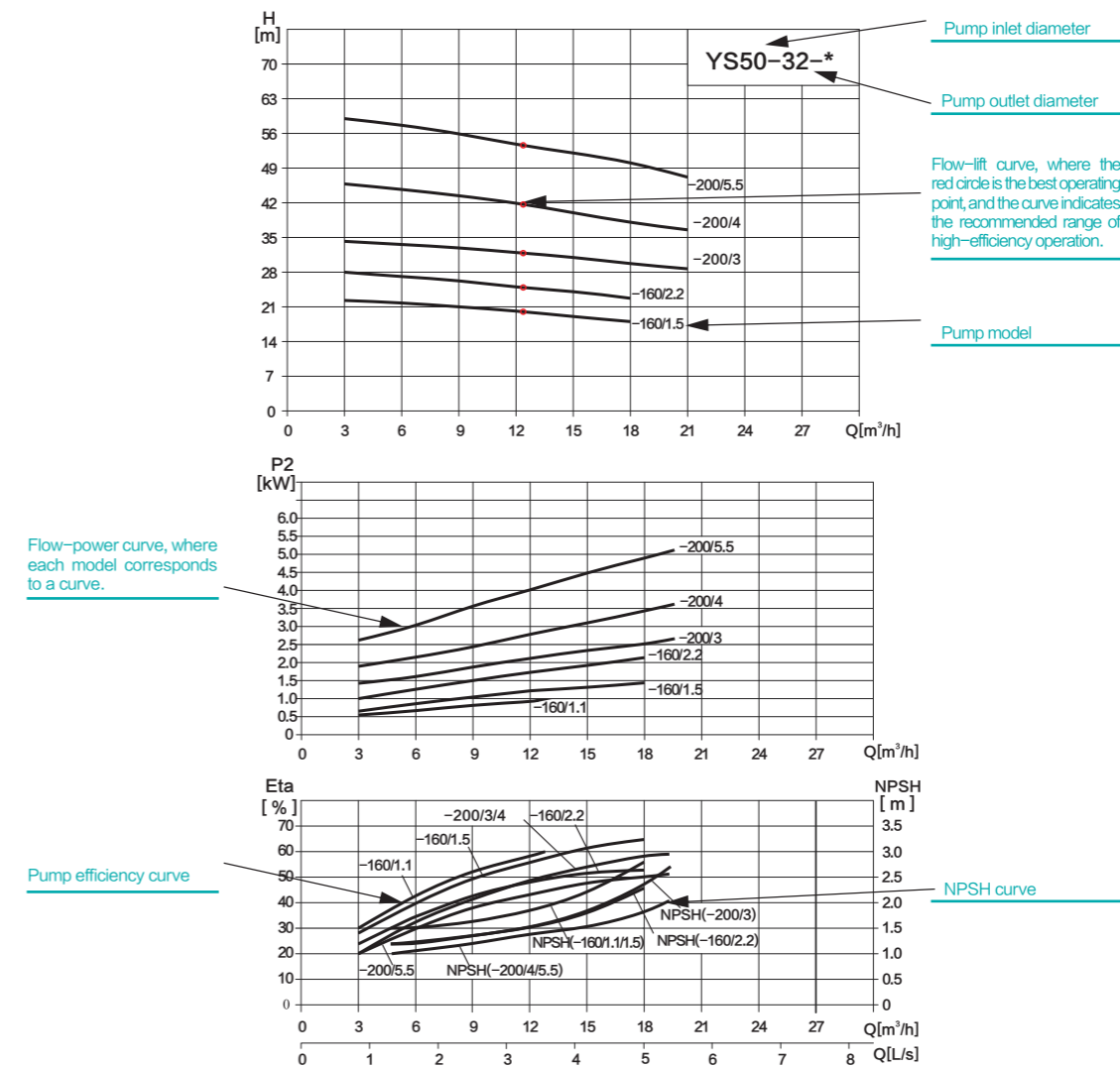

Applicable Principles of Performance Curves

1. The curve tolerance complies with ISO9906, Annex A;
2. The test medium is 20° C clean water that does not contain any solid impurity and air;
3. All curves are based on 3 × 380V electric motors with the Synchronous speed 3000rpm;
4. The curves are applicable to liquid with the kinematic viscosity $\nu = 1\text{mm}^2/\text{s}$ (1cst);
5. In order prevent the danger of overheating, the pump shall be ensured to operate within the range of curves to avoid overload of motor.

YS50-32-*

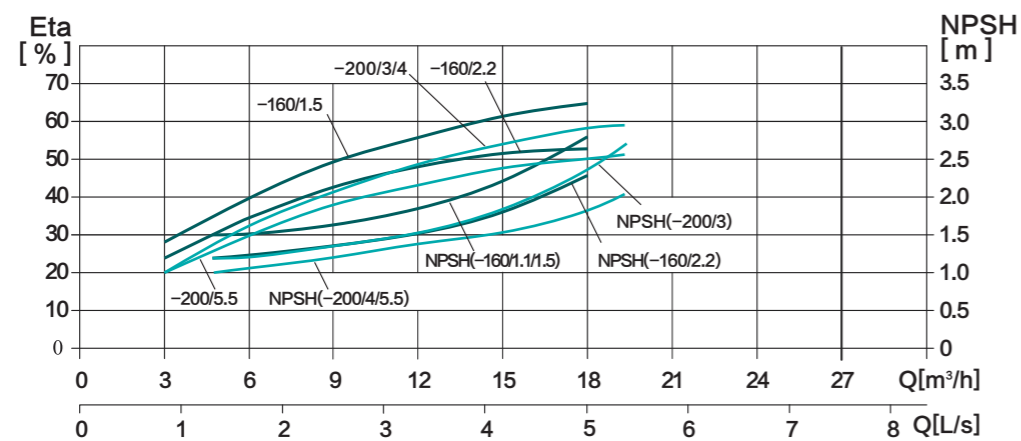
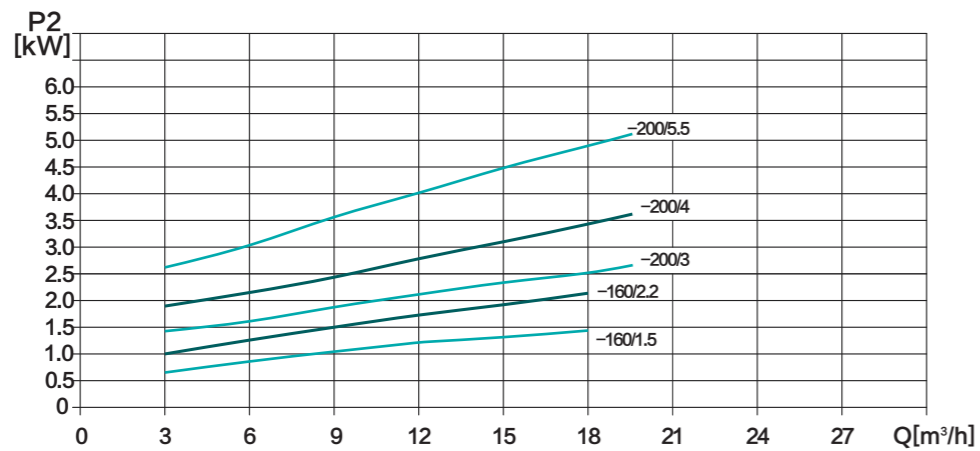
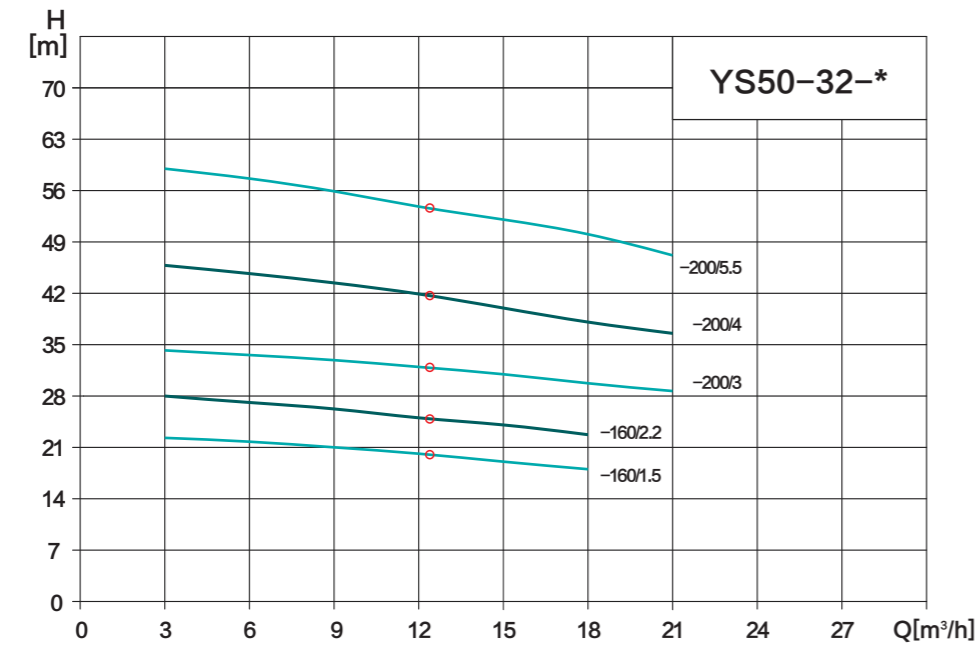

Performance Table

Pump model	Motor power(kW)	Q (m³/h)	3	6.3	9	15	18	20
YS50-32-160/1.5	1.5	H (m)	22.5	22	21	19	18	/
YS50-32-160/2.2	2.2		28	27	26.3	24	22.5	/
YS50-32-200/3	3		34.9	34.1	33.3	31	29.8	28.9
YS50-32-200/4	4		45.7	44.8	43.7	40.7	39	37.7
YS50-32-200/5.5	5.5		25.5	57.2	56	52.5	50	48.5

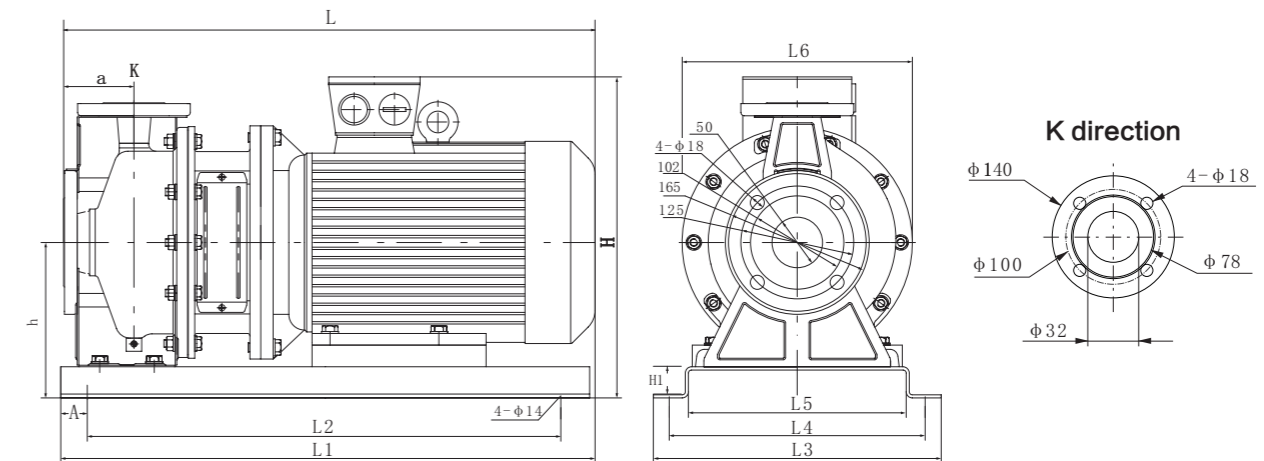

Dimensions and Weight

Pump model	Dimensions												Weight (kg)
	A	a	H	H1	h	L	L1	L2	L3	L4	L5	L6	
YS50-32-160/1.5	37	82	296	20	152	503	500	430	280	240	192	210	27
YS50-32-160/2.2	37	82	296	20	152	503	500	430	280	240	192	210	29
YS50-32-200/3	40	82	386	40	200	538	530	460	330	290	242	300	43
YS50-32-200/4	35	82	386	40	200	558	550	460	330	290	242	300	48
YS50-32-200/5.5	32	82	498	40	200	769	660	580	370	330	282	300	77

Note: The dimensions of the single phase motor and explosion-proof motor are subject to change. You can consult SHIMGE for more details.

YS65-40-*

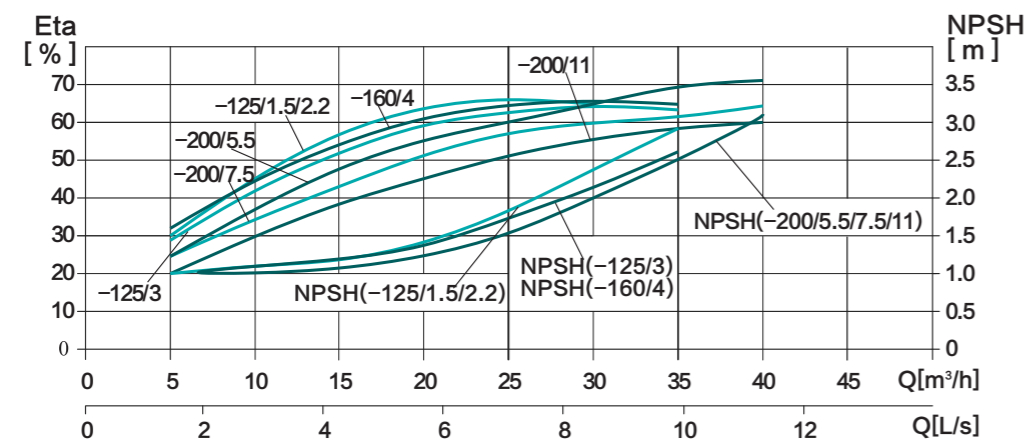
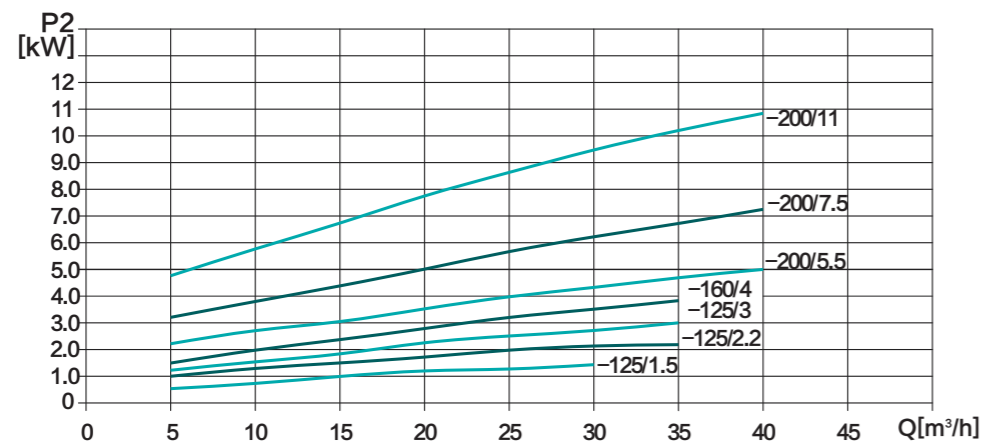
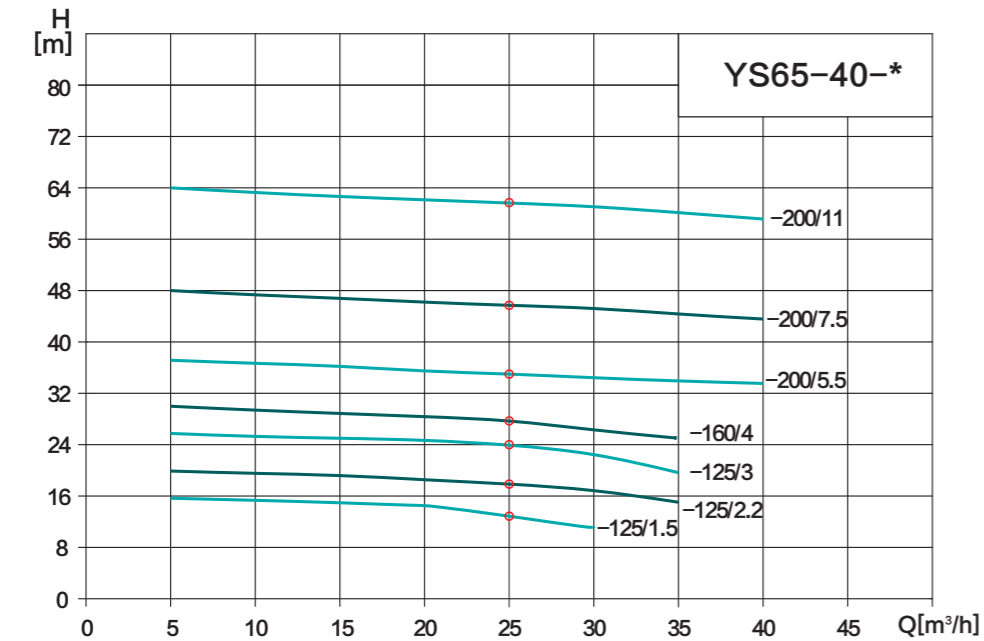

Performance Table

Pump model	Motor power(kW)	Q (m³/h)	5	10	15	20	25	30	35	40
YS65-40-125/1.5	1.5	H (m)	15.5	15.4	15	14.4	13	11.3	/	/
YS65-40-125/2.2	2.2		20	19.7	19.5	19	18	16.7	15.2	/
YS65-40-125/3	3		25.7	25.3	25.1	24.8	24	22.3	20.3	/
YS65-40-160/4	4		30	29.7	29.3	28.9	28	26.5	24.5	/
YS65-40-200/5.5	5.5		37.4	37.2	36.7	36.4	36	35.5	34.6	33.3
YS65-40-200/7.5	7.5		48	47.5	47	46.6	46	45.2	44.5	43.3
YS65-40-200/11	11		64	63.5	63	62.5	62	61.5	60.5	59

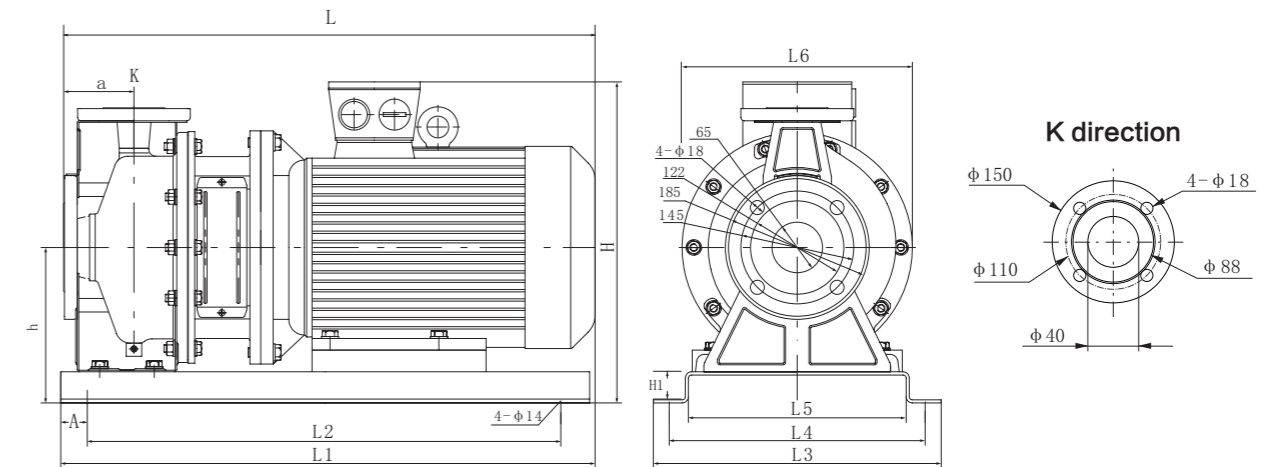

Dimensions and Weight

Pump model	Dimensions												Weight (kg)
	A	a	H	H1	h	L	L1	L2	L3	L4	L5	L6	
YS65-40-125/1.5	37	82	294	40	152	503	500	430	280	240	192	210	23
YS65-40-125/2.2	37	82	267	40	152	503	500	430	280	240	192	210	25
YS65-40-125/3	37	82	267	40	152	533	530	460	300	260	212	250	37
YS65-40-160/4	37	82	267	40	152	553	550	480	330	290	242	250	42
YS65-40-200/5.5	50	100	498	40	200	784	660	580	370	330	282	300	78
YS65-40-200/7.5	50	100	498	40	200	784	660	580	370	330	282	300	82
YS65-40-200/11	50	100	540	40	200	963	770	690	420	380	332	350	161

Note: The dimensions of the single phase motor and explosion-proof motor are subject to change.

You can consult SHIMGE for more details.

YS65-50-*

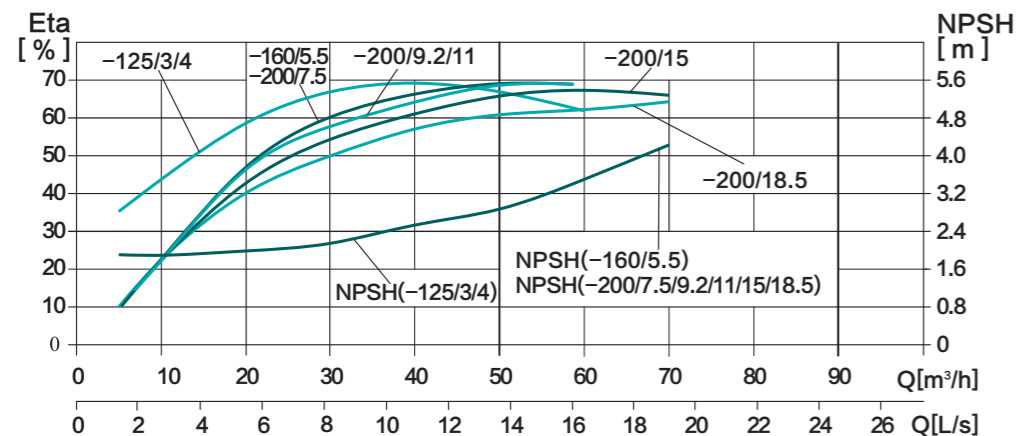
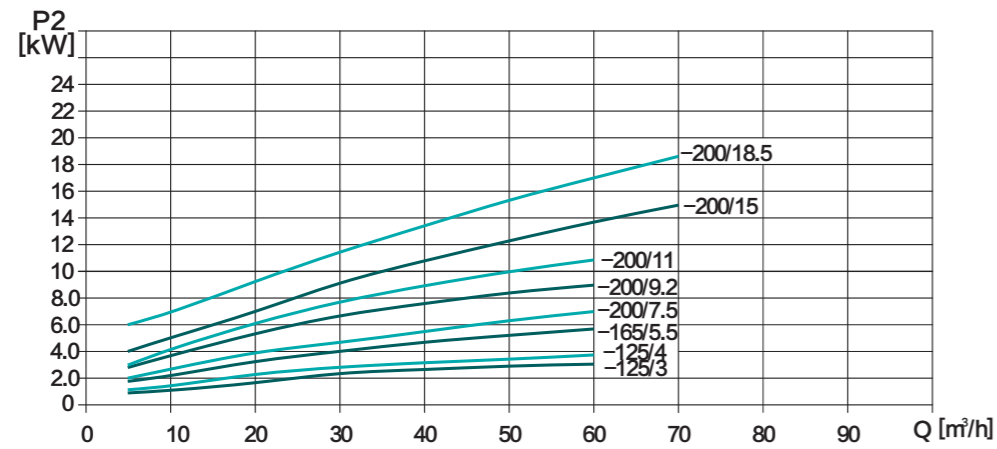
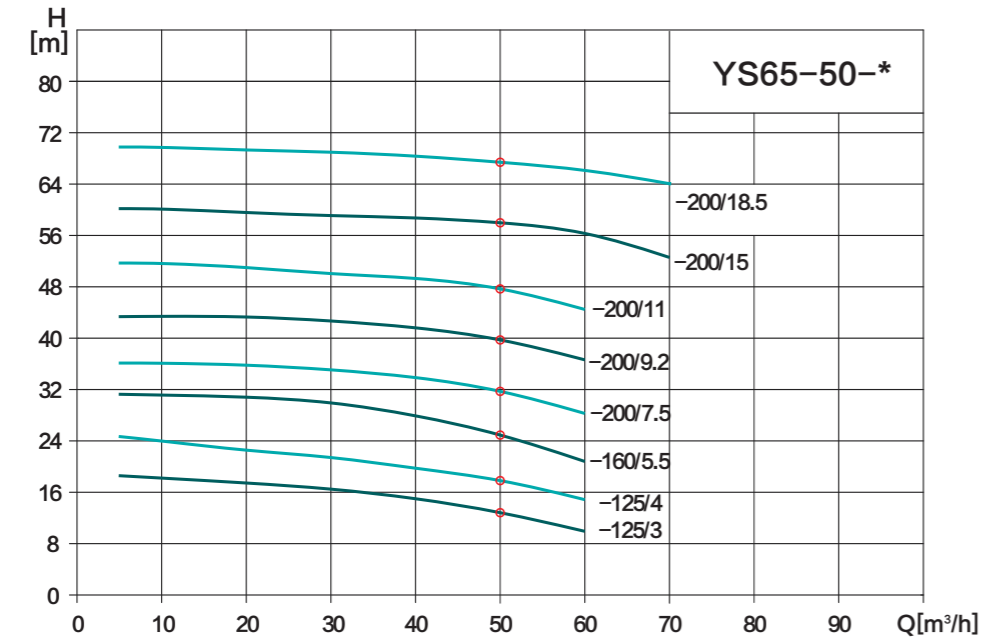

Performance Table

Pump model	Motor power(kW)	Q (m³/h)	5	10	20	30	40	50	60	70
YS65-50-125/3	3	H (m)	18	17.8	17.2	16.4	15.1	13	10	/
YS65-50-125/4	4		24.2	24.2	23.6	22.6	20.7	18	14.8	/
YS65-50-160/5.5	5.5		31.6	31.5	31	30	28	25	21.5	/
YS65-50-200/7.5	7.5		36.3	36.6	36.4	35.6	34.1	32	29.6	/
YS65-50-200/9.2	9.2		43.5	43.5	43.5	43	42	40	37.5	/
YS65-50-200/11	11		51.5	51.5	51	50	49.3	48	45.6	/
YS65-50-200/15	15		59.7	59.7	59.6	59.5	59	58	56.2	53
YS65-50-200/18.5	18.5		70.2	70.2	70.1	70	69.1	68	66.4	64

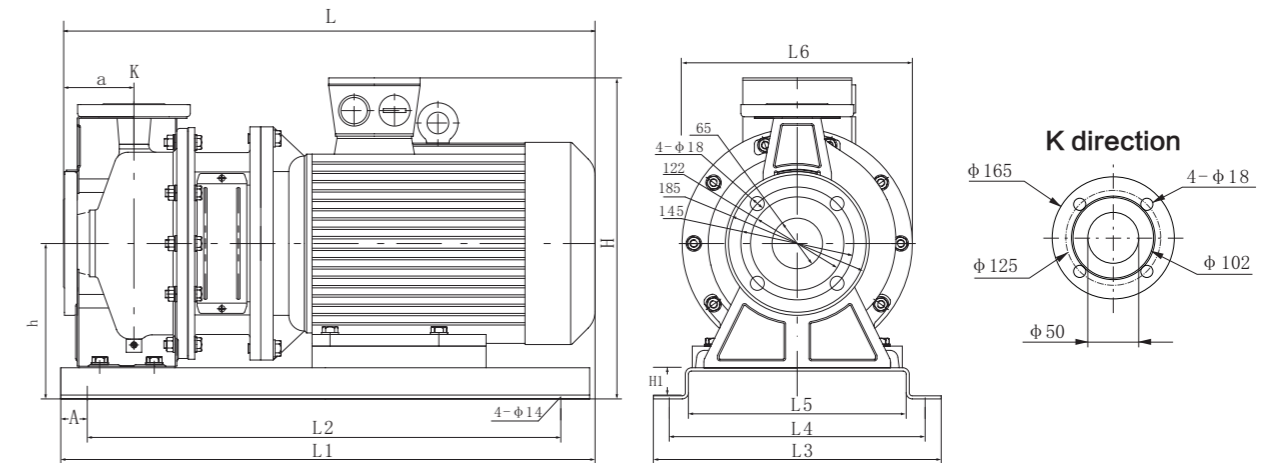

Dimensions and Weight

Pump model	Dimensions												Weight (kg)
	A	a	H	H1	h	L	L1	L2	L3	L4	L5	L6	
YS65-50-125/3	41	86	338	40	200	533	530	468	330	290	262	250	39
YS65-50-125/4	41	86	338	40	200	553	550	490	330	290	262	250	44
YS65-50-160/5.5	50	100	498	40	200	784	660	580	370	330	282	300	78
YS65-50-200/7.5	50	100	498	40	200	784	660	580	370	330	282	300	82
YS65-50-200/9.2	50	100	540	40	200	963	660	580	370	330	282	300	85
YS65-50-200/11	50	100	540	40	200	963	770	690	420	380	332	350	161
YS65-50-200/15	50	100	540	40	200	963	770	690	420	380	332	350	171
YS65-50-200/18.5	50	100	540	40	200	963	810	730	420	380	332	350	188

Note: The dimensions of the single phase motor and explosion-proof motor are subject to change.

You can consult SHIMGE for more details.

YS80-65-*

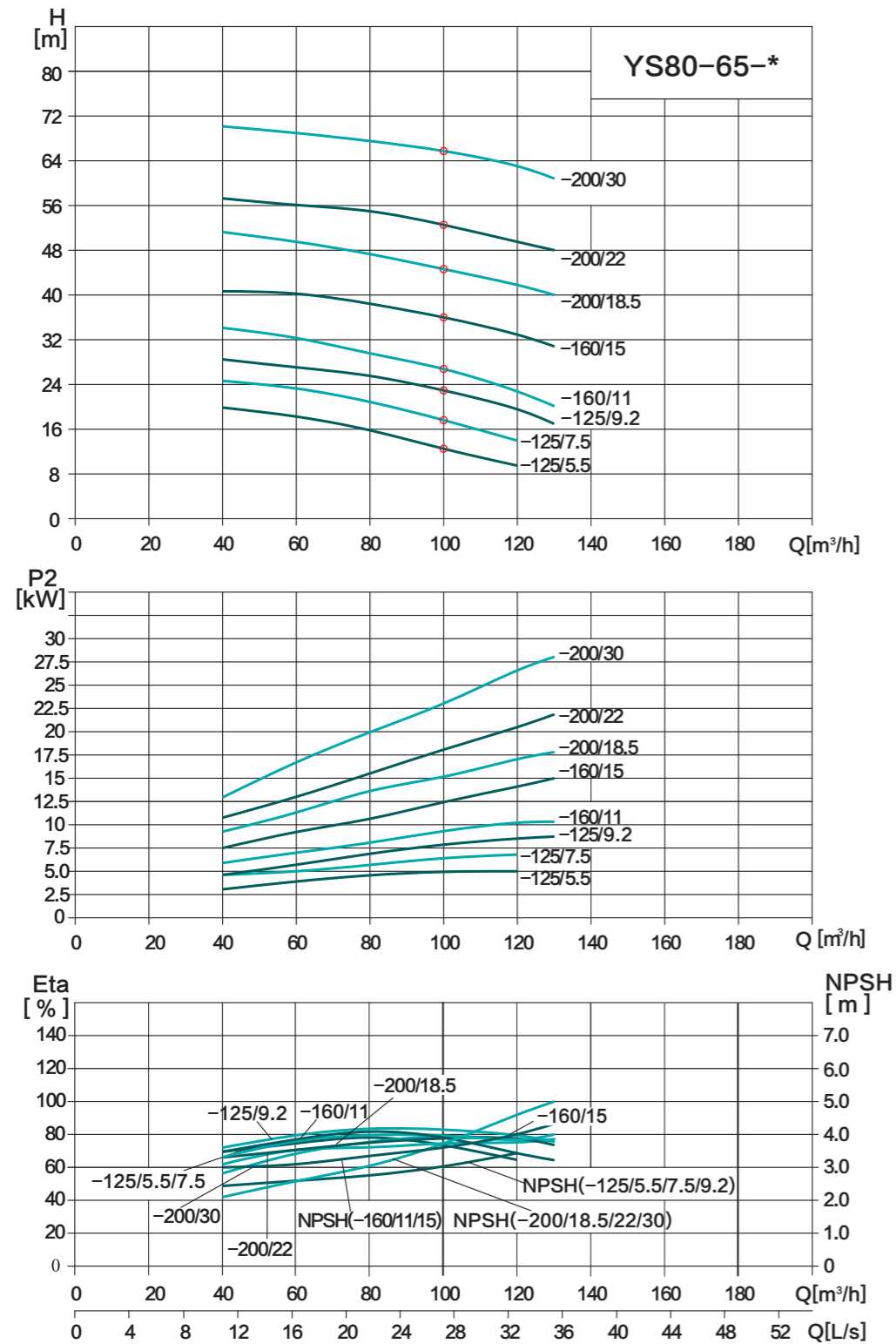

Performance Table

Pump model	Motor power(kW)	Q (m³/h)	40	50	60	70	80	90	100	110	120	130
YS80-65-125/5.5	5.5	H (m)	19.3	18.7	18	17	15.8	14.8	13	11.4	9.7	/
YS80-65-125/7.5	7.5		24.5	23.8	23.1	22.2	21	19.6	18	16.2	14.1	/
YS80-65-125/9.2	9.2		28.1	27.8	27.3	26.6	25.7	24.3	23	21.8	20.1	18.3
YS80-65-160/11	11		33.9	33	32.2	31.3	29.9	28.8	27	25.1	22.9	20.7
YS80-65-160/15	15		41.8	41.1	40.4	39.5	38.6	37.6	36	34.8	33	31
YS80-65-200/18.5	18.5		51	50.5	49.6	48.7	47.6	46.3	45	43.5	42.2	40.2
YS80-65-200/22	22		57.7	57.2	56.8	55.9	55.1	54	53	51.6	49.7	48.2
YS80-65-200/30	30		70.2	70.2	69.6	68.9	68.2	67.1	66	64.6	63.3	61.4

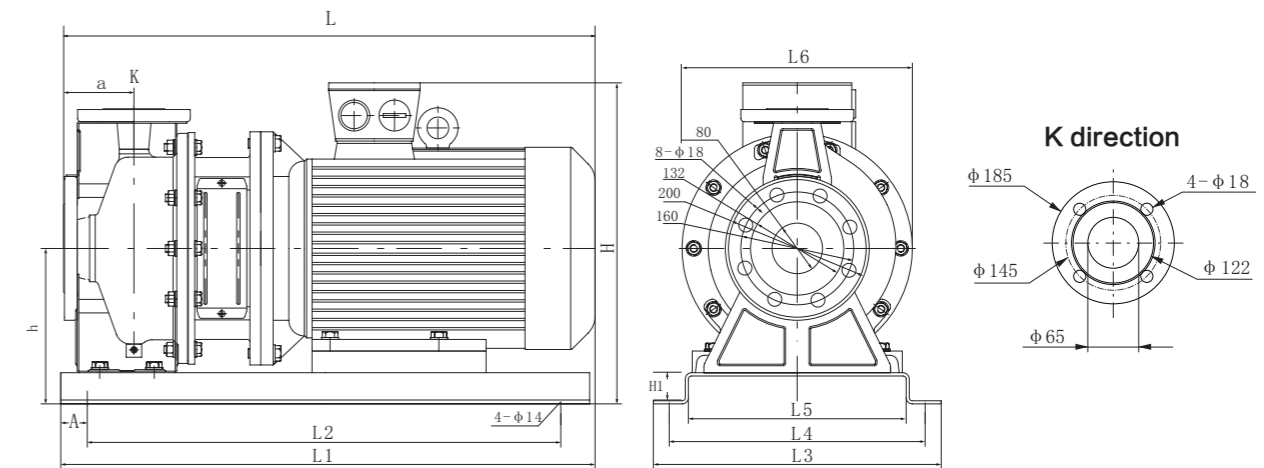

Dimensions and Weight

Pump model	Dimensions												Weight (kg)
	A	a	H	H1	h	L	L1	L2	L3	L4	L5	L6	
YS80-65-125/5.5	50	100	413	40	200	690	660	590	370	330	282	300	79
YS80-65-125/7.5	50	100	413	40	200	690	660	590	370	330	282	300	83
YS80-65-125/9.2	50	100	413	40	200	690	660	590	370	330	282	300	87
YS80-65-160/11	50	100	456	40	200	790	770	690	420	380	332	350	163
YS80-65-160/15	50	100	456	40	200	790	770	690	420	380	332	350	173
YS80-65-200/18.5	50	100	476	40	200	830	810	730	420	380	332	350	190
YS80-65-200/22	50	100	500	40	200	880	860	780	455	415	367	350	220
YS80-65-200/30	50	100	550	40	200	950	930	850	495	455	407	400	292

Note: The dimensions of the single phase motor and explosion-proof motor are subject to change. You can consult SHIMGE for more details.

YS100-80-*

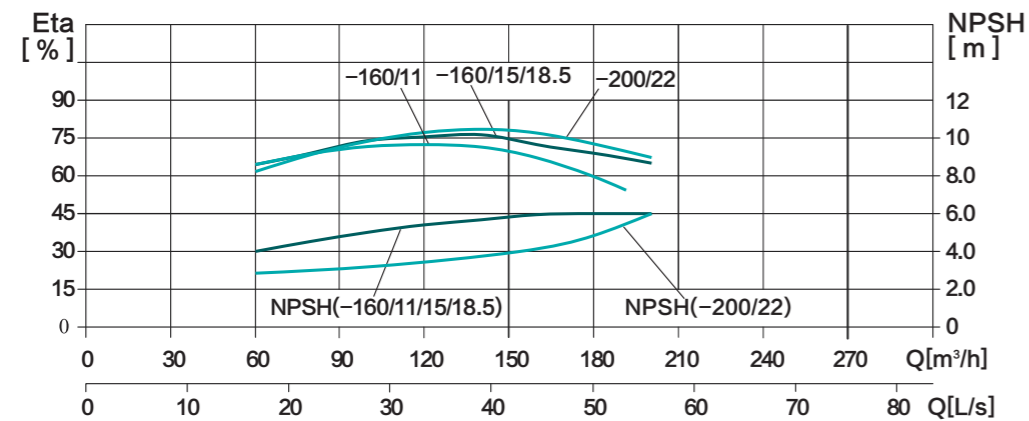
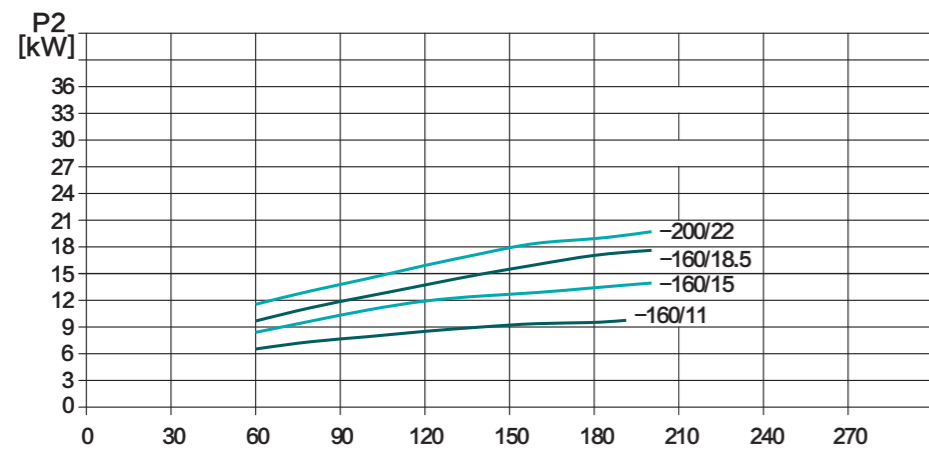
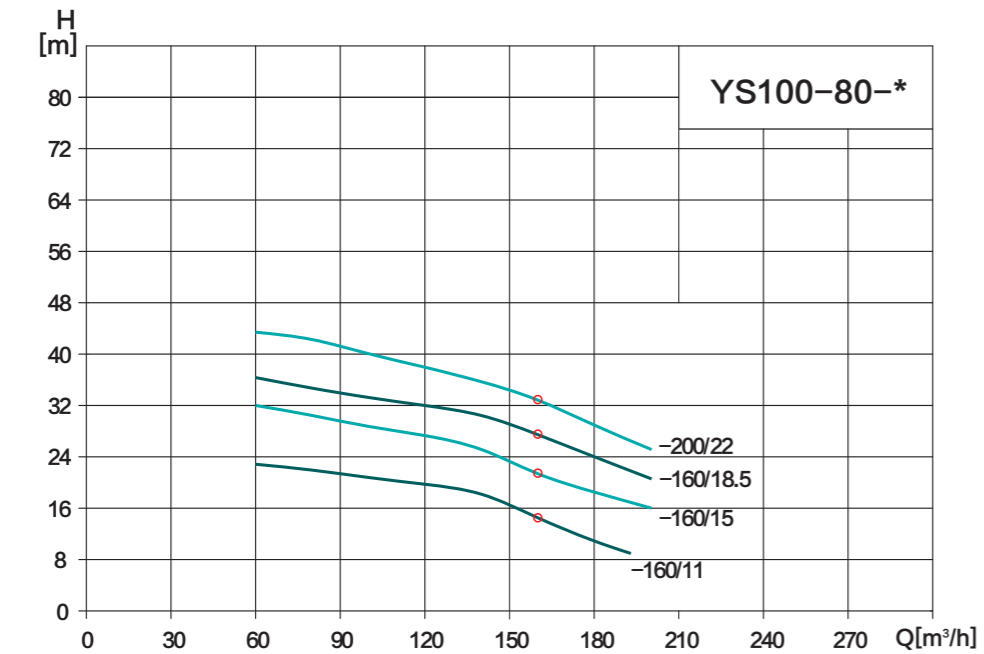

Performance Table

Pump model	Motor power(kW)	Q (m³/h)	60	80	100	120	140	160	180	192	200
YS100-80-160/11	11	H (m)	23.8	22.7	21.1	19.7	17.6	15	11.8	9.7	/
YS100-80-160/15	15		32.3	30.8	29.1	27.2	25.1	22	18.8	/	16.1
YS100-80-160/18.5	18.5		36.2	35.2	33.8	32.7	31	28	24.8	/	21.5
YS100-80-200/22	22		43.5	42	39.7	38.3	35.9	33	29	/	24.9

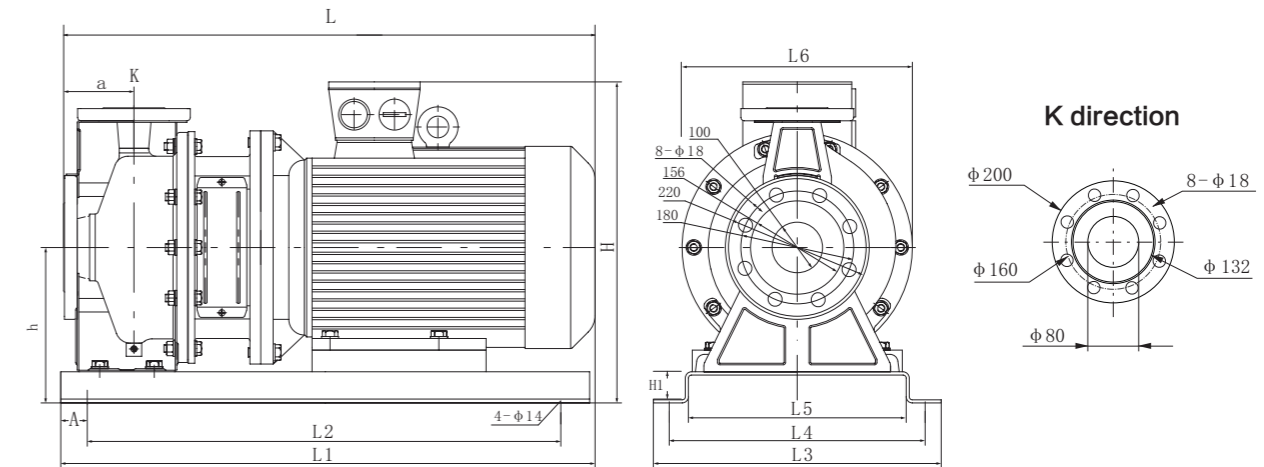

Dimensions and Weight

Pump model	Dimensions												Weight (kg)
	A	a	H	H1	h	L	L1	L2	L3	L4	L5	L6	
YS100-80-160/11	50	125	476	40	200	830	810	730	420	380	332	350	163
YS100-80-160/15	50	125	476	40	200	830	810	730	420	380	332	350	173
YS100-80-160/18.5	50	125	476	40	200	870	850	770	420	380	332	350	185
YS100-80-200/22	50	125	500	40	200	920	890	810	455	415	367	350	220

Note: The dimensions of the single phase motor and explosion-proof motor are subject to change. You can consult SHIMGE for more details.